



DATASOUND

- LABORATORIES -

.....

EMBEDDING THE FUTURE



**Electronic
Design**



**Panel
PC / HMI**

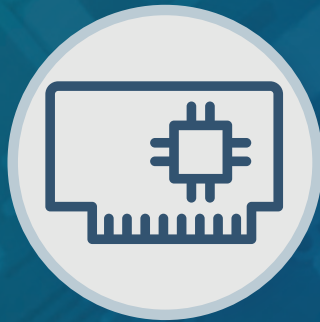

**Single Board
Computer**



**Industrial
PC**

Why choose DSL?

- Over 25 Years Industry Experience
- 5 Years Warranty on all Products
- Evaluation Products Available
- Lifetime Technical Support

Our Services

- Electronic Design
- Production Management
- Assembly and Test
- Bespoke BIOS Creation
- Industrial Embedded PC Solutions



Call us on +44(0)1462 675530



Email us at sales@dsl-ltd.co.uk



www.dsl-ltd.co.uk

Features

- Stainless steel front bezel Display
- Flat front panel touch screen
- Projected Capacitive Touch or Glass (Option)
- Wide range DC 9~36V power input
- IP66 compliant front panel / IP69K for option
- VGA, DP, DVI/HDMI input
- OSD on the rear side
- System Power LED light
- High brightness LCD for option

Specifications

I/O Port	
VGA	1 x VGA
DVI	1 x DVI-D (share with HDMI)
DP	1 x DP
HDMI	1 x HDMI (share with DVI-D)
Audio	1 x Audio line-in phone jack
OSD Control	OSD at rear side
Membrane	On board controller, extendable key pad from connector
Power	1 x 3-pin terminal block for DC 9~36V power input
Others	1 x USB type B for touch control Optional I/O: 1 x Speaker

Display	Standard	
Display Type	12.1" TFT LCD	12.1" TFT LCD
Max. Resolution	800 x 600	1024 x 768
Max. Color	16.2M	16.2M
Luminance (cd/m ²)	450	500
View Angle	178(H) / 178(V)	160(H) / 140(V)
Contrast	1500:1	700:1
Backlight Lifetime	50,000 hrs	30,000 hrs

Display	High Brightness (option)	
Display Type	12.1" TFT LCD	12.1" TFT LCD
Max. Resolution	800 x 600	1024 x 768
Max. Color	262K/16.2M	262K/16.2M
Luminance (cd/m ²)	1000	1000
View Angle	178(H) / 178(V)	160(H) / 140(V)
Contrast	700:1	700:1
Backlight Lifetime	50,000 hrs	50,000 hrs

Touch Screen	
Type	Projected Capacitive Touch (For FABS-112P model) Glass-AR (For FABS-112G model)
Interface	USB Interface
Light Transmission(%)	Over 90%

Power	
Power Input	DC 9~36V
Power Consumption	TBD

Dimensions

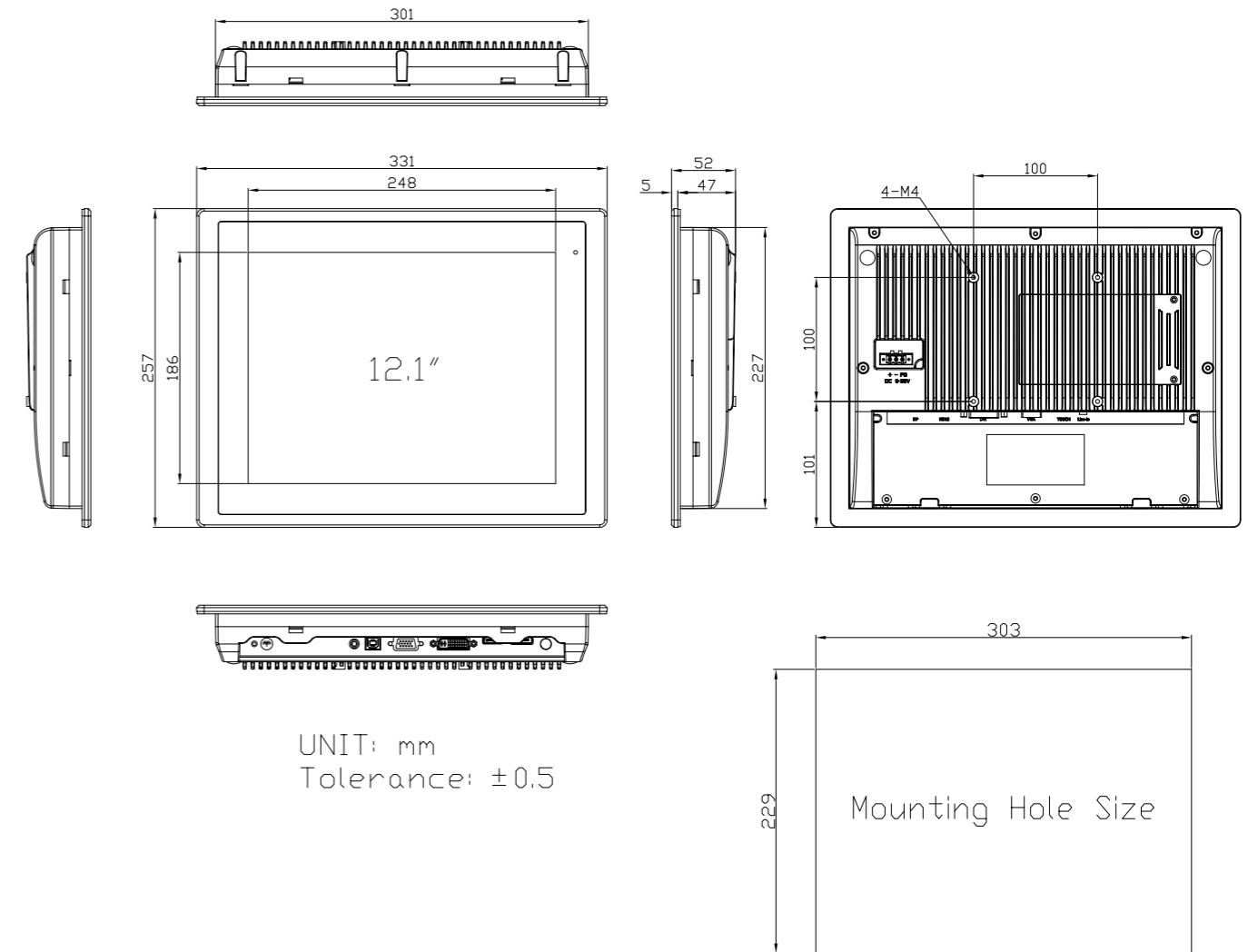

Mechanical	
Construction	Aluminum die-casting chassis
Mounting	Panel mount / VESA mount 100 x 100
IP Rating	IP66 compliant front panel / IP69K(option)
Dimensions (WxHxD)	331 x 257 x 52 mm
Net Weight	TBD

Environmental	
Operating Temperature	0~50°C
Storage Temperature	-30~70°C
Storage Humidity	10 to 90% @ 40°C, Non-condensing
Certificate	CE/FCC, Class A