



DATA SOUND - LABORATORIES -

.....
EMBEDDING THE FUTURE



**Electronic
Design**



**Panel
PC / HMI**

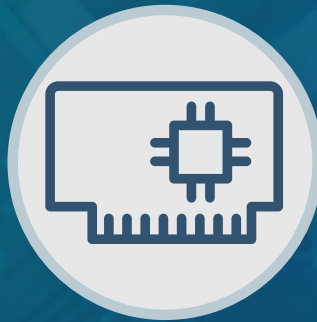

**Single Board
Computer**



**Industrial
PC**

Why choose DSL?

- Over 30 Years Industry Experience
- 5 Years Warranty on all Products
- Evaluation Products Available
- Lifetime Technical Support

Our Services

- Electronic Design
- Production Management
- Assembly and Test
- Bespoke BIOS Creation
- Industrial Embedded PC Solutions



Call us on +44(0)1462 675530



Email us at sales@dsl-ltd.co.uk



www.dsl-ltd.co.uk

Features

- 8" Industrial Compact Size Panel PC
- Intel Apollo Lake N4200/ N3350 (option)
- On Board 4GB/ 8GB DDR3L 1600MHz
- Flat front panel touch screen
- IP66 compliant front panel
- Optional projected capacitive touchscreen support 7H anti-scratch surface
- DC 9~36V wide-ranging power input
- High Brightness 1,000 nits for option

Specifications

System	
CPU	Onboard Intel Apollo Lake N4200 (4 Core, 1.1GHz) / N3350 (2 Core, 1.1GHz) (option)
System Chipset	SoC
Memory	Onboard 4GB/ 8GB (option) DDR3L 1600MHz

I/O Port	
USB	2 x USB 3.0 type A
Serial / Parallel	1 x DB-9 RS-232/422/485, COM1 (Default RS-232) 1 x RS-232 DB-9, COM2
Audio	1 x Audio Line Out
LAN	2 x GbE LAN RJ-45
Power	1 x 3-pin DC power input terminal 1 x 2-pin connector for power on/off
Option	VESA Stand 4G LTE/Wi-Fi/BT

Storage Space	
HDD	1 x MO-297 SATA SSD bay (Easy Accessible)

Expansion	
Expansion Slot	1 x Internal Mini-PCIe slot full size 1 x SIM card holder / Micro SD card reader

Display	Standard	High Brightness Optional
Display Type	8" TFT-LCD	8" TFT-LCD
Max. Resolution	800 x 600	800 x 600
Max. Color	16.2M	16.2M
Luminance (cd/m ²)	350	1000
View Angle	140(H) / 120(V)	140(H) / 125(V)
Contrast	500:1	500:1
Backlight Lifetime	40,000 hrs	50,000 hrs

Touch Screen	
Type	Resistive Touch (for AR Model) Projected Capacitive Touch (for AP Model) Glass (for AG model)
Interface	USB
Light Transmission(%)	Resistive Touch Window: over 80% Projected Capacitive Touch: over 90%

Dimensions

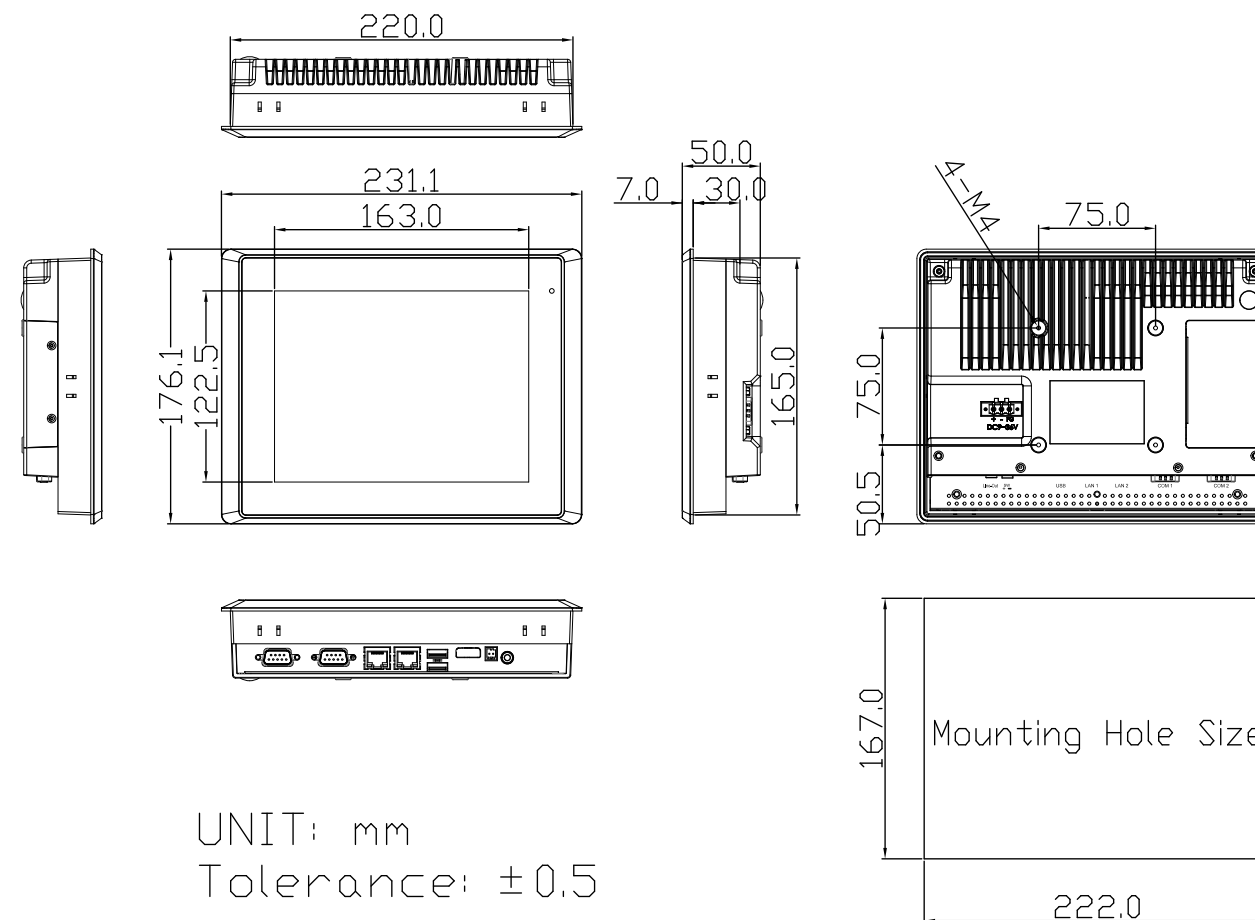

Power	
Power Input	DC 9~36V
Power Consumption	ARCHMI-808AP:28W

Mechanical	
Color	RAL 9007
Construction	Aluminum die-casting chassis
Mounting	Panel Mount, VESA 75 x 75
Dimensions (WxHxD)	231.1mm x 176.1mm x 50mm
IP Rating	IP66 Compliant Front Bezel
Net Weight	1.9 kg

Environmental	
Operating Temperature	0~50/ -20~60 (option)
Storage Temperature	-30~70°C
Humidity	10 to 95% @ 40°C, non-condensing
Certificate	CE/FCC Class A

Operating System Support	
Windows 10 IoT Enterprise	